

DUTCH GABLE FREESTANDING CARPORT



STRATCO OUTBACK® ASSEMBLY INSTRUCTIONS.

Your complete guide to building a FREESTANDING Outback DUTCH GABLE CARPORT

BEFORE YOU START

Carefully read these instructions. If you do not have all the necessary tools or information, contact Stratco for advice. Before starting lay out all components and check them against the delivery docket. The parts description identifies each key part, and the component location diagram indicates their fastening position.

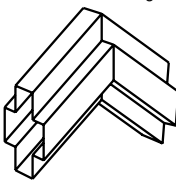
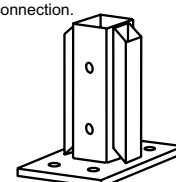
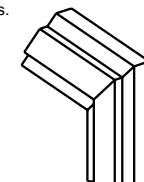
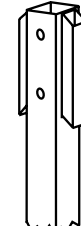
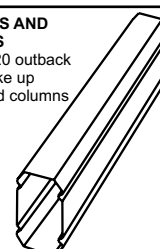
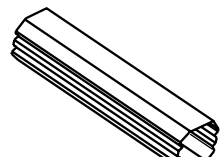
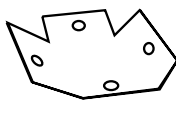
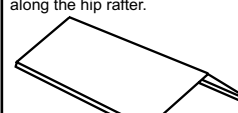
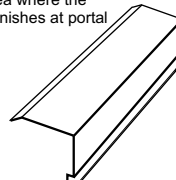
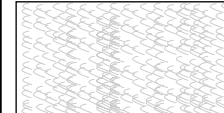
PARTS DESCRIPTION

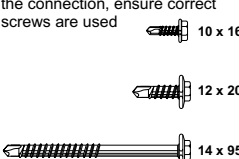
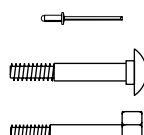
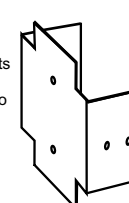
<p>RIDGE KNUCKLE Slots inside the gable rafters to form connection at the ridge</p> 	<p>FOOTING PLATE Slots inside column to form on concrete footing connection.</p> 	<p>EAVES KNUCKLE Slots inside gable rafter and column to form connection at eaves.</p> 	<p>FOOTING KNUCKLE Slots inside column to form an in ground footing connection</p> 	<p>COLUMNS AND RAFTERS Pre cut 120 outback beam make up rafters and columns</p> 
<p>PURLINS Purlins provide support for cladding</p> 	<p>HIP PLATE Connects purlins to the hip rafter.</p> 	<p>RIDGE CAP This flashing covers the roof sheets at the gable ridge.</p> <p>HIP FLASHING Covers the roof sheet ends along the hip rafter.</p> 	<p>BARGE CAP The barge cap covers the area where the deck finishes at portal frame</p> 	<p>INFILL PANELS Sufficient number of sheets are provided, from which the required dutch gable infill panels can be cut.</p> 
<p>WEATHER STRIP Weather strip supports infill panel and covers the sheet ends at the collar tie</p>  <p>PANEL STRIPS Panel strips attach to the infill panel where applicable</p> 	<p>HEX HEAD SELF DRILLING SCREWS Screw types vary depending upon the connection, ensure correct screws are used</p> 	<p>BOLTS AND RIVETS Bolt types vary depending upon the connection, ensure the correct fixings are used</p> 	<p>68 mm PURLIN BRACKET This bracket fastens end purlin supports in place and front purlins to end purlin supports</p> 	

COMPONENT LAYOUT

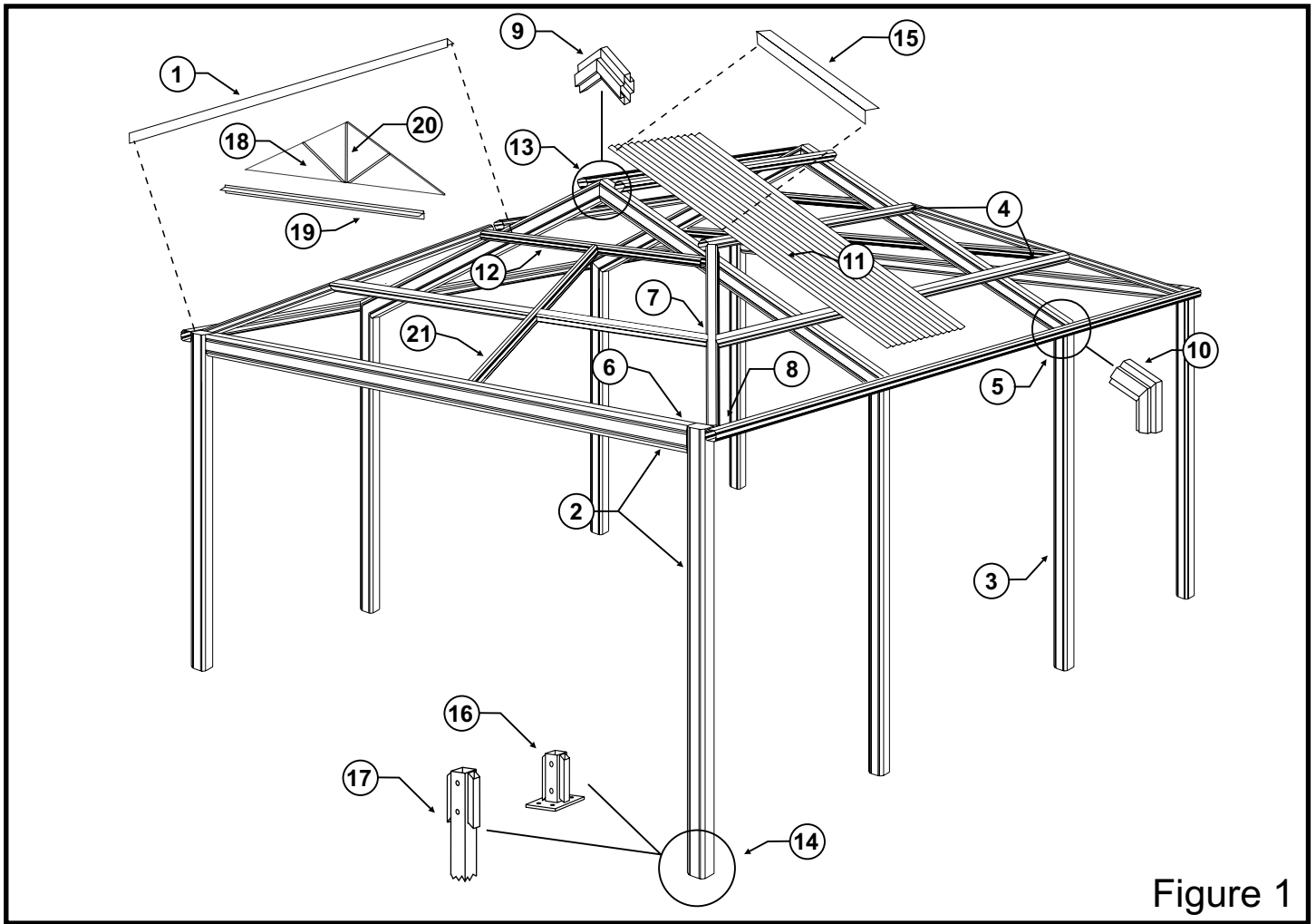
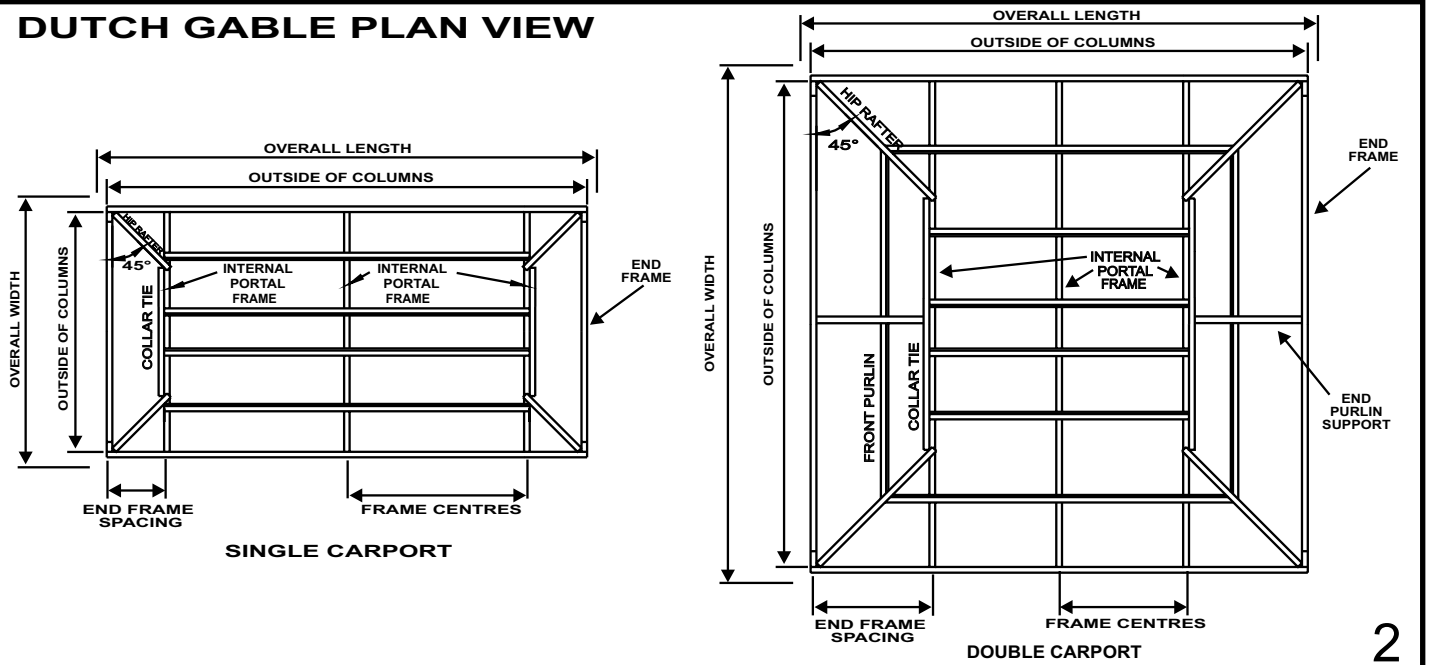

Figure 1

- | | | | |
|----------------------------|------------------------|----------------------|----------------------|
| ① Hip Flashing | ⑦ Hip Plate Connection | ⑬ Ridge Connection | ⑱ Infill Panel |
| ② End Frame | ⑧ Seated Connection | ⑭ Footing Connection | ⑲ Weather Strip |
| ③ Portal Frame | ⑨ Ridge Knuckle | ⑮ Barge Cap | ⑳ Panel Strips |
| ④ Purlins | ⑩ Eaves Knuckle | ⑯ Footing Plate | ㉑ End Purlin Support |
| ⑤ Eaves Purlin Connection | ⑪ Roof Cladding | OR | |
| ⑥ 120 Beam-Beam Connection | ⑫ Collar Tie | ⑰ Footing Knuckle | |

DUTCH GABLE PLAN VIEW



CONSTRUCTION

MARKING OUT CARPORT POSITION

A) IN GROUND FOOTING

Place stakes at the carport column locations using the appropriate dimensions from the drawings supplied.

Note: These column locations are very critical, as the roof sheet lengths are governed by these dimensions.

Therefore ensure the end frame spacing and the width of the carport are exactly as specified in the drawings.

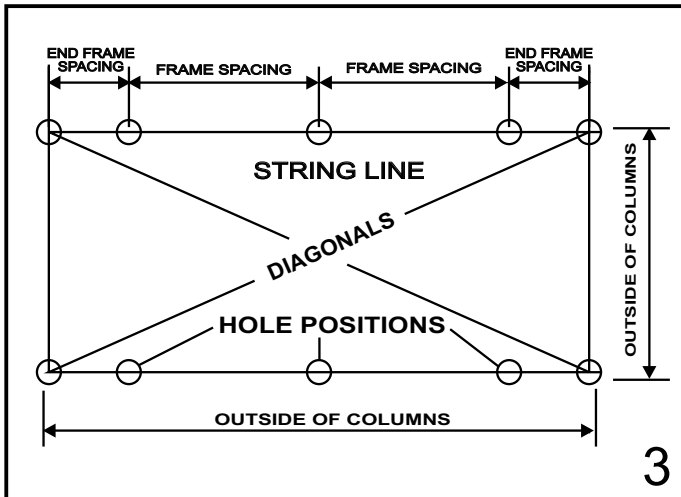

Tie string lines between the stakes to ensure the footings are in line. Check the dimensions and diagonals for squareness.

The end frame spacing, gives the centreline spacing between the rectangular end portal frame and the internal gable portal frame. Where more than two internal portal frames are required, space at the dimensions specified on the drawings supplied.

Dig holes to the required size as stipulated by your Council Application Form. Place bricks in the bottom of the holes to give a solid base onto which the footing knuckles can be positioned.

B) ON CONCRETE FOOTING

If bolting columns onto existing concrete slab check to ensure concrete dimensions are as specified by your Council. Stratco does not take any responsibility for concrete failure.

Mark the position of the columns as shown in Figure 4. using the appropriate dimensions from the drawings supplied.

Note: These column locations are very critical, as the roof sheet lengths are governed by these dimensions. Therefore ensure the end frame spacing and the width of the carport are exactly as specified in the drawings supplied.

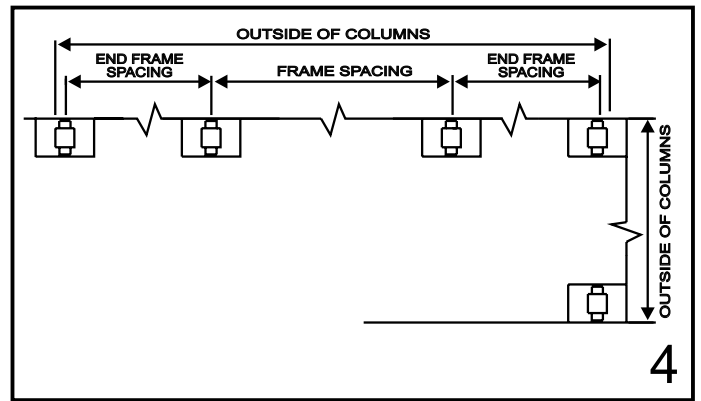

The end frame spacing, gives the centreline spacing between the rectangular end portal frame and the internal gable portal frame. Where more than two internal portal frames are required, space at the frame spacing dimensions specified on the drawings supplied.

Place the footing plate in the appropriate locations as specified on the drawings supplied. The orientation of the base plate is such that the smaller dimension runs along the width as shown in Figure 4.

Mark the position of the holes through the existing holes in the footing plate. Remove the footing plate and drill into concrete using the values given in Table 1.

NOTE: Do not drill completely through slab, as chemical anchors require a solid base to bear against.

Use chemical anchors (for size refer to Table 1) together with the appropriate anchor capsules and install according to the manufacturers recommendations.

Leave the Stud Bolt undisturbed for the minimum time specified by the manufacturer for the resin to cure. Curing times are dependent on the concrete temperature at the time of installation.

Note: Footing plates are not fixed until portal frames have been assembled.

CARPORT	CHEMICAL ANCHOR SIZE (mm)	HOLE DIAMETER (mm)	HOLE DEPTH (mm)
CARPORTS < 5000mm WIDE IN W41 WIND SPEED	M10x130	12	95
CARPORTS 5000mm WIDE IN W41 WIND SPEED	M12x160	14	115

TABLE 1

ASSEMBLE PORTAL FRAMES

Place the three knuckle connections inside portal frame members, using a hammer to tap in position (a block of timber should be used whenever hammering to avoid damaging paintwork).

Important note: Knuckles are colour coded as follows, ensure that the correct knuckle is used for each connection.

- 22° Ridge Knuckle - Green
- 22° Eaves Knuckle - Red
- 30° Eaves and Ridge Knuckle - Yellow

Join all frame members; first insert eaves knuckle into column to rafter joint, next the footing knuckle/base plate into the column base, and then finally the ridge knuckle into the two halves of the frame at the ridge (refer to figure 5 for knuckle locations).

Use a hammer at the eaves knuckle to join the two sides together as shown in Figure 5. If knuckles are difficult to insert apply a lubricant or grease.

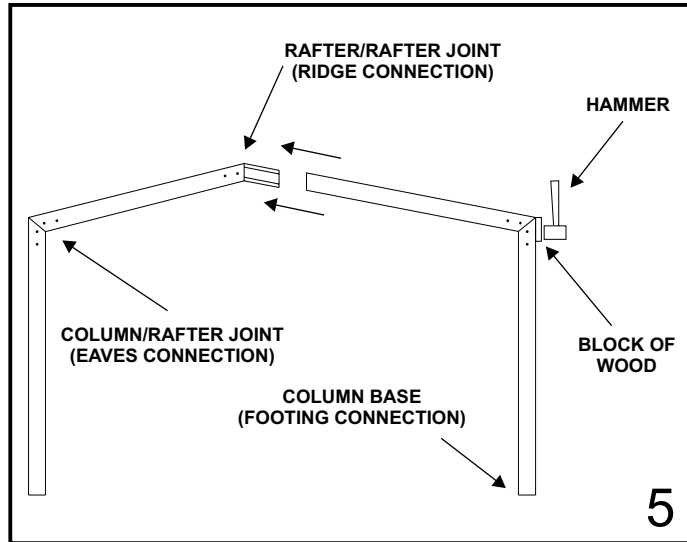

EAVES AND RIDGE CONNECTION

Screw together eaves and ridge connections, using two 12 x 20 hex head self drilling screws both sides of each member and two 12 x 20 hex head self drilling screws through the top (double flange side) of each member. Pilot holes indicate screw locations as shown in figures 6 and 7.

Make sure that the two ends are flush at the connection, leaving no gaps.

Important Note: An eaves purlin connection bracket is attached as part of the eaves connection to both sides of the portal frame using two 12 x 20 hex head self drilling screws as detailed in figure 7 (pre drill for ease of fastening).

FOOTING CONNECTION

For all footing connections, bolt together through pre drilled holes using M10 cup head bolts as shown in figure 8. Ensure that the bolt heads are all on the same side of the frame.

Mark the purlin centres on the top of the portal frames.

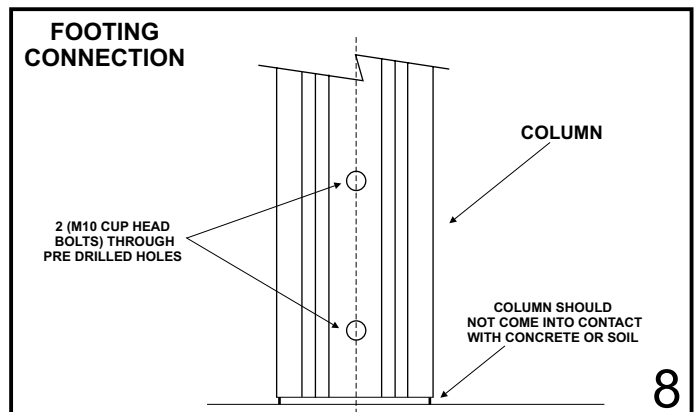
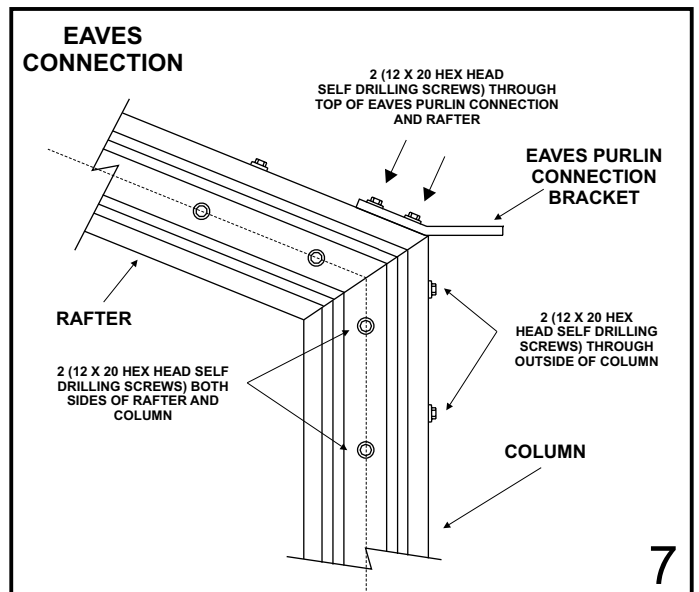
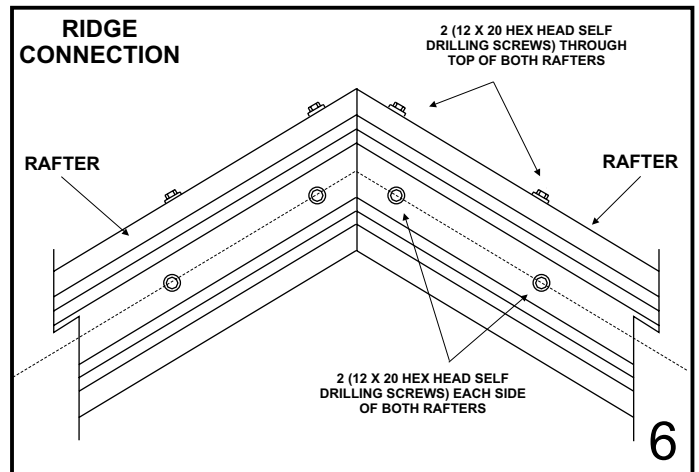

ASSEMBLE END FRAMES

Pre-drill a 10 mm diameter hole 34 mm down from the top of the column through the centre of the double flange side (eaves purlin will bolt onto here) as shown in Figure 9.

Attach end wall beam-column connection 30 mm down from the top inside face of column, using two 10 x 16 hex head self drilling screws.

Note: Double flange must always be on the outside of the frame.

Slip end rafter over connection and fasten with four coloured 10 x 16 hex head self drilling screws as in Figure 9.

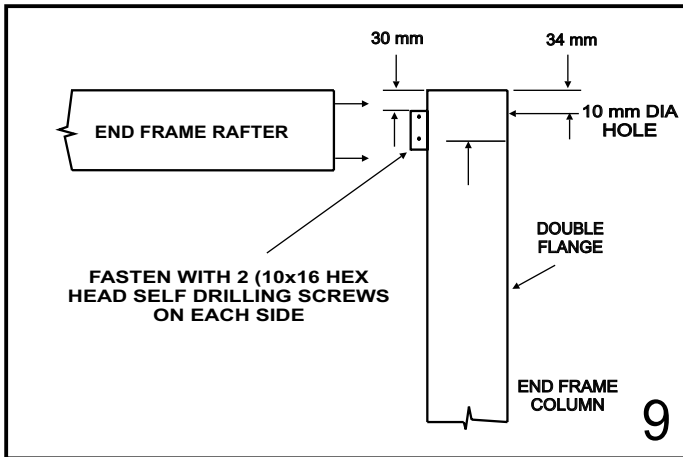

PRE-DRILL PURLINS

Note: All purlins are supplied to suit the individual Heritage designs, It is important you refer to your plan and check purlin lengths before cutting.

For extra long carports where you need to join two purlins, make sure they are joined over a portal frame and that the top lap faces the same way for both purlins to achieve a neat joint.

Cut the eaves purlins to correct length. Pre-drill the eaves purlins with 10 mm diameter holes at the end portal frame locations. Only drill holes through the single side rib of the eaves purlin (see Figure 10).

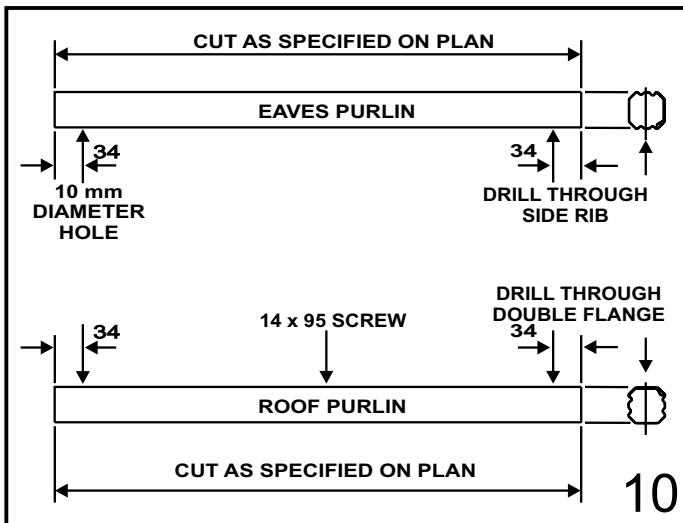

ERECT END FRAMES

A) IN GROUND FOOTING

Stand the end portal frame in the appropriate footing location and temporarily brace in position with clamps and struts (see Figure 11).

Bolt the eaves purlins to the sides of the end frame columns using the 1.0 x 3/8 hex bolts provided, so that the purlins are level with the top of the column as shown in Figure 12.

Raise the other end frame and secure to eaves purlins. Ensure the ends of the purlins are flush with the outside faces of the end frames and the diagonal distances between the end frames are equal.

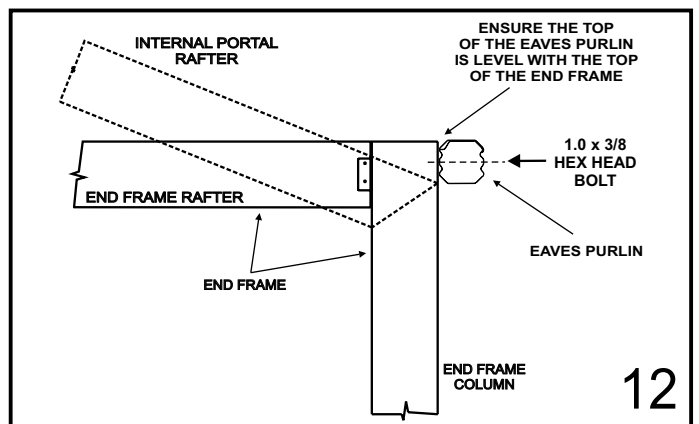
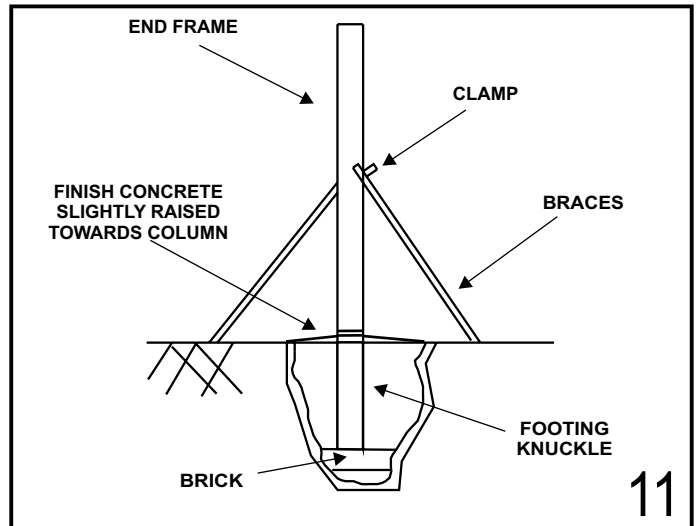

Check column base is at the ground surface, and the clear opening between columns is correct. Finally and most importantly check that the columns are vertical.

Concrete the footings and leave overnight to cure.

Note: The concrete should be finished slightly raised towards the column, ensuring water runs away from the column, see Figure 11.

Important Note: If concrete or soil is in permanent contact with the colorbond columns, corrosion will result in the base of the coloured column. Refer to the "Selection, Use and Maintenance of Stratco Steel Products" brochure for complete details of maintenance requirements.

B) ON CONCRETE FOOTING

Select the end rectangular portal frames. Place the footing plates in position and bolt securely.

ERECT PORTAL FRAMES

Now stand the internal portal frames in position, so that the eaves purlins rest on the eaves connection brackets. Fasten the eaves purlin to the eaves connection through the underside of the bracket using two coloured 10 x 16 hex head self drilling screws (see Figure 18).

Note: The drawings supplied define the positioning of the internal portal frames relative to the end frames and as mentioned these are very critical.

CHECK FRAMES

Now that the portal frames are in place, check the dimensions between portals are correct, and all portals are in line and vertical. Most importantly check the diagonal measurements are equal.

ROOF STRUCTURE

Refer to Figure 2

Pre-drill the roof purlins with 14 x 95 hex head self drilling screws at the internal portal locations, through the double flange first. Fasten one of these roof purlins at the ridge as shown in Figure 13. Check roof diagonals to ensure sloping roof area is square.

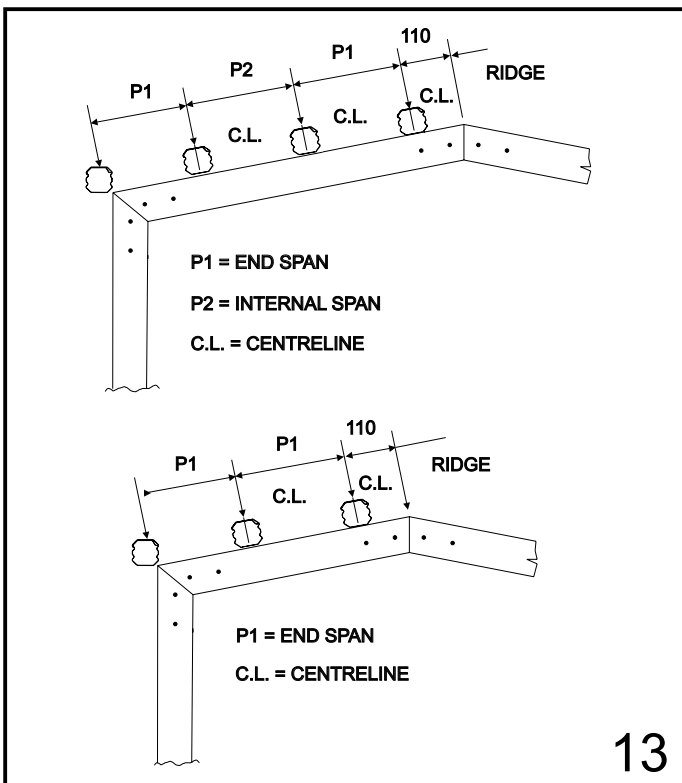

Screw the four seated hip rafter connections to the top inside corners of the structure, level with the top of the eaves purlin. Fix with two 10 x 16 hex head self drilling screws, see Figure 14.

Lift hip rafter onto seated connection ensuring double thickness flange is at the top. The hip rafter angles away from the rectangular end frame at 45° and is screwed onto the internal gable frame as shown in figure 14.

Note: This 45° angle is critical in ensuring correct shape of the Dutch Gable and therefore the sheet lengths.

Cut hip rafters to length and pre-drill with one large 14 x 95 hex head self drilling screw at the end, ensuring double thickness flange is at the top. Position hip rafter on the seated hip connection and fasten underside with two coloured 10 x 16 hex head self drilling screws.

Screw the remaining end onto the top of the internal portal frame. Do not over tighten, preventing crushing of the hip rafter.

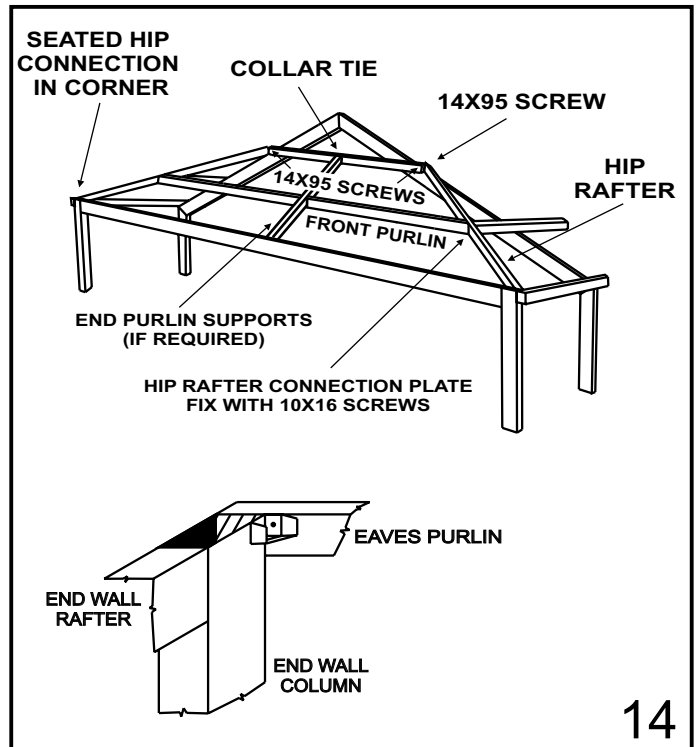

Single Size Carport

Attach remaining roof purlins as shown in Figure 13.

Note: Only 3 purlins for single carport, one purlin at eaves, one at ridge and one intermediate. Quantities may vary depending on roof cover and carport width.

Double Size Carport

Fasten the remaining roof purlins at the ridge location and 900 mm further down the rafter on each side. Position a purlin (first roof purlin - see Figure 15) 900 mm up the rafter from the eaves purlin (double flange on top).

Measure and cut a 45° mitre at the ends to fit flush against the hip rafter. Pre-drill with 14 x 95 self drilling screw at the internal rafter locations and fasten in place.

Fix hip rafter connection plate to the underside of the hip rafter/side purlin joint using 10 x 16 hex head self drilling screws in the holes provided. Where end purlin supports are not required, locate front purlin on exposed connection plate, measure and cut a 45° mitre to fit flush with hip rafter. Screw in place (see Figures 14 and 15).

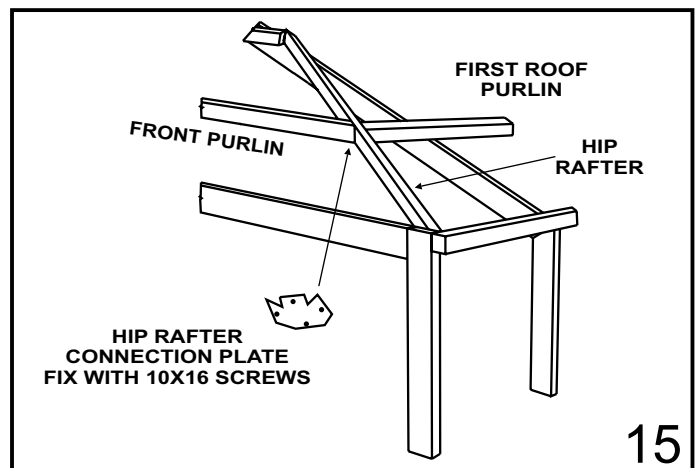

COLLAR TIE

The collar tie spans horizontally across the outside of the internal gable portal frames. It aligns with the top of the hip rafters, so that the front roof sheets can run continuously over the rectangular end rafter, front purlin and the collar tie.

Again pre-drill first through the double flange material with one large 14 x 95 hex head self drilling screw at each end, and fasten to side of gable rafters.

END PURLIN SUPPORTS

End purlin supports (68mm purlins) are only required if indicated in the drawings supplied. End purlin supports span between the collar tie and the end frame and are to be fastened in place using the 68mm purlin bracket before front purlin/s are screwed in place.

If only one end purlin support is required fasten one purlin bracket mid-span of collar tie and a second mid-span of the end frame (inline with the top of 120 end rafter) using two 10 x 16 hex head self drilling screws per bracket (Figure 16). If two end purlin supports are required fasten brackets at third points along both collar tie and end rafter (ie, 2 along collar tie and 2 along end rafter, Figure 17).

Measure, cut and mitre end purlin supports to fit flush between collar tie and end frame ensuring double flange is on top. When two end purlin supports are required legs on purlin brackets may need to be bent inward or outward slightly to accommodate angle between end purlin supports and frame.

Fasten end purlin supports in place using two 10 x 16 hex head self drilling screws per bracket per side of end purlin support. Cut (and mitre if necessary) front purlin/s to span between end purlin supports. 68mm purlin brackets are to be fastened to end purlin supports where they meet front purlin/s and front purlin/s are screwed in place.

Note : This procedure applies to both ends of the Dutch Gable unit.

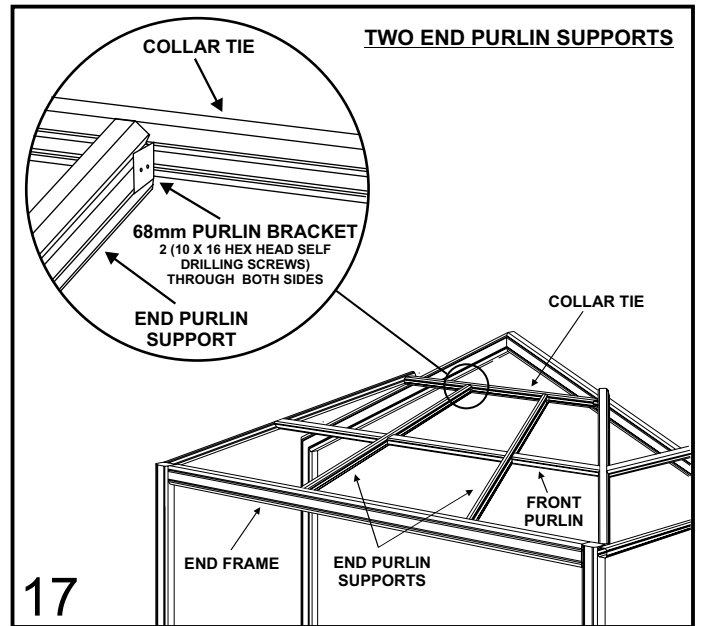
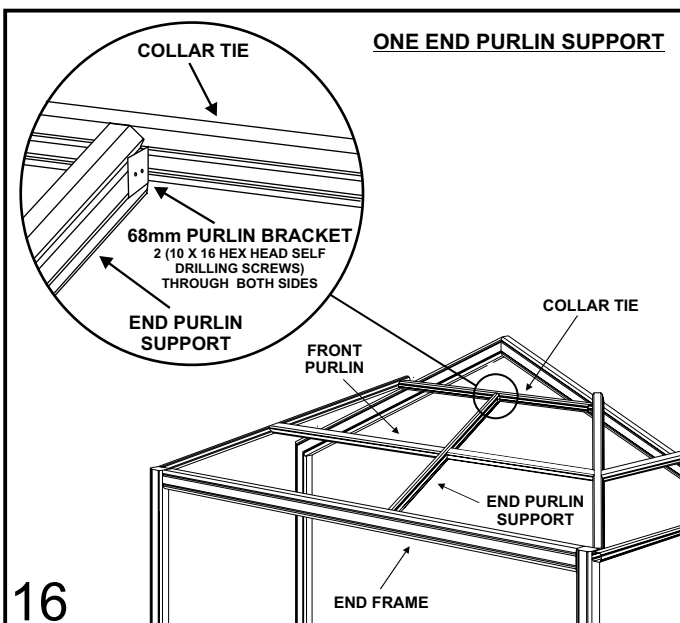

CONCRETE REMAINING FOOTINGS (IN CONCRETE FOOTING)

Once the carport frame is complete concrete the remaining footings. Only concrete the galvanised tube footing stumps.

Note: The concrete should be finished slightly raised towards the column, ensuring water runs away from the column, see figure 11.

Important Note: If concrete or soil is in permanent contact with the colorbond columns, corrosion will result in the base of the colored column. Refer to the "Selection, Use and Maintenance of Stratco Steel Products" brochure for complete details of maintenance requirements.

GUTTER ASSEMBLY

(a) Measure and cut gutters to the appropriate length (ie back length of gutter should equal outside frame dimensions + 30mm). Rivet and silicone seal.

(b) Notch hole in gutter and insert downpipe pop so that downpipe is in line with a portal column.

Note: If your column footings are in ground you would have installed your portal frames with a slight fall towards downpipe end. Ensure that the gutter is notched at the right end.

However if you are bolting the footings on to existing concrete slab, and there is a slight fall in the slab ensure that the downpipe is at the lower end of the slab to help the water run off). Fasten the pop in place using rivets and silicone seal.

(c) Cut 70 mm long metal strips from band supplied. Pop rivet these tags to the top of the eaves purlins and end frame rafters at 1200 mm centres. Rivet the back lip of the gutter to these tags, ensuring the back face of the gutter is held vertical as shown in Figure 18. Rivet and silicone seal.

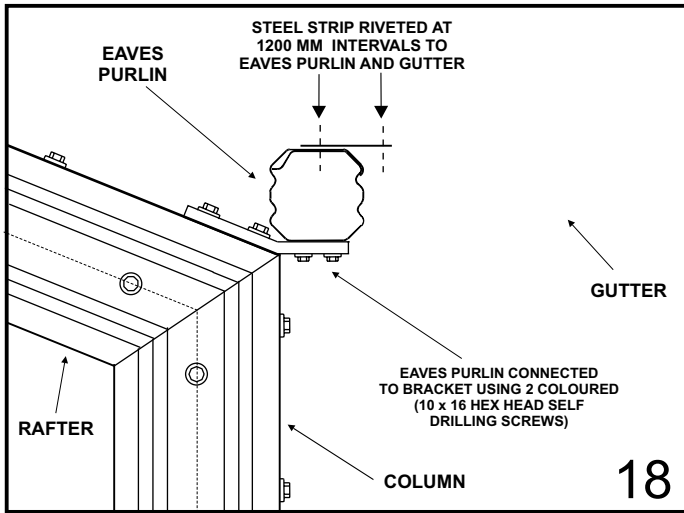

18

ROOF SHEETING

Begin sheeting the internal framework of the carport roof with the large CGI sheets, allowing for a 40 mm overhang at the eaves into the gutter (see Figure 19). Always have the lap joint facing away from the prevailing wind direction on all carport roof faces. Lap final sheet to fit last span. Position, mark and cut triangular sheets for sides of Dutch gable roof section.

Note: triangle offcuts are re-used on the opposite side of roof, so make sure the cuts are clean and accurate. Make sure offcuts are positioned correctly before laying the longer sheets, so that capping direction can be determined.

Crest fix CGI sheeting with 12 x 35 Roofing Screws using 5 per sheet for end spans and 3 per sheet for internal spans. Work from one side of the structure to the other, marking and cutting triangular sheets as appropriate. Pan fix the triangular sheets to the hip rafter with 10 x 16 hex head self drilling screws.

Sheet the front and rear faces of the Dutch gable roof. Crest fix the sheets and triangular offcuts at the end rafter and front purlin locations. Pan fix with 10 x 16 hex head self drilling screws at collar tie and hip rafter locations.

Attach the gutter straps at 1200 mm centres by crest-fixing to roof sheets with 10 x 16 Screws. Construct two 85 mm downpipe offsets from the downpipe lengths supplied and attach to pops with rivets. Fasten the downpipes and straps to the adjoining column.

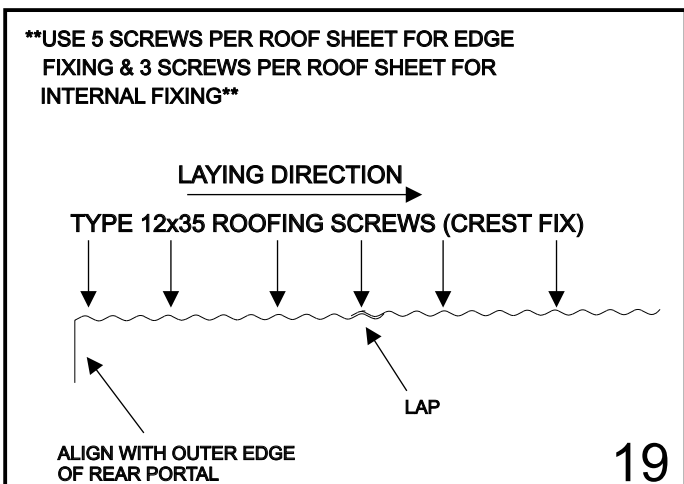

19

FIX FLASHINGS AND INFILL PANELS

Refer to Figure 20 for all flashing positions. In general fasten all flashings using 3 mm pop rivets at approximately 600 mm centres. However when fixing flashings to the infill panels use split-tail rivets.

a) Dutch Gable Weather Strip: Position flashing along collar tie member with leading edge resting on top of roof sheets. Notch flashing to fit around gable rafters and fasten with pop rivets.

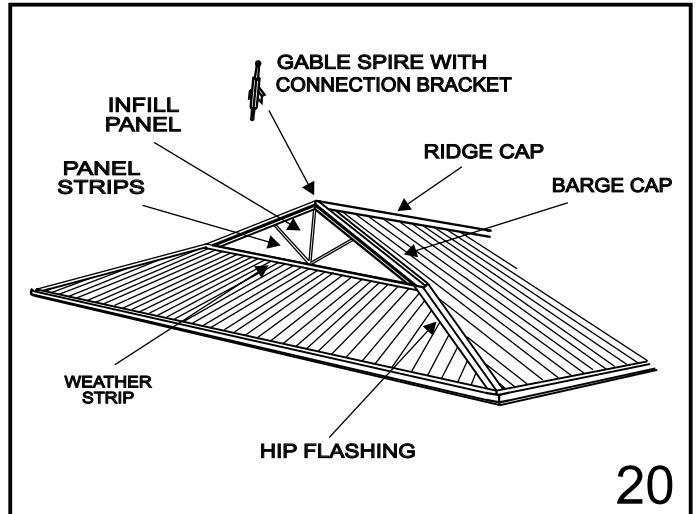

20

b) Cut triangular gable infill panels (from the rectangular panel provided), to fit the vertical gable frames located at each end of the Dutch gable roof. Paint the panels to the desired colour before installing. Rest the panels on the weather strip flashing. Fasten panels onto adjoining rafters through the top groove using 12 x 35 roofing screws spaced at 1000 mm centres.

c) Hip Capping: Attach the small lengths hip capping to cover hip rafter seams, and mitre to fit the gutter corner.

d) Front and Rear Barges: The front and rear barge caps are fixed to the crest of the CGI roof and front of the gable infill panel. Mitre flashing to overlap weather strip and hip cap so as to give a neat water tight finish at the Dutch gable junction. Silicone joint if necessary.

e) If ordered, fix decorative strips to dutch gable infill panel.

f) Gable Spires (Finials): If decorative gable spires are desired, nail the spire bracket to the back of the wooden spire, and rivet in position at the top of the ridge.

g) Ridge Cap: The ridge flashing can now be attached. The ridge should finish flush with the end of the carport, overlapping the front and rear barge capping to provide a weather proof seal.

HELPFUL TIPS

Leave plastic coating on members until they are about to be fastened to the structure. This will help prevent scratching of the colorbond finish.

Sweep the roof and clean gutters after the completion of work. Ensure any swarf and rivet stubs are removed as they can cause unsightly rust stains.

Leave bracing struts in position until structure is complete and concreted in. This stabilises the structure and holds it square during construction.

Double check all measurements and drilling locations before proceeding.

Regularly check framework for squareness and vertical alignment to make sure it hasn't moved during construction.

MAINTENANCE

Regular washing or hosing of the inside and outside of your Stratco Heritage Outback will ensure it looks its best at all times. Refer to the "Selection, Use and Maintenance of Stratco Steel Products" brochure for complete details of maintenance requirements.



SOUTH AUSTRALIA

GEPPS CROSS Telephone (08) 8349 5555

125 Cavan Road, GEPPS CROSS

• **ST AGNES Telephone (08) 8263 8955**
128 Tolley Road, ST AGNES

• **RICHMOND Telephone (08) 8349 5559**
263 Richmond Road, RICHMOND

• **LONSDALE Telephone (08) 8349 5559**
Cnr. Dyson & O'Sullivan Beach Roads, LONSDALE

• **GAWLER Telephone (08) 8522 1132**
150 Murray Street, GAWLER

• **WHYALLA Telephone (08) 8645 7344**
Ian Street, WHYALLA NORRIE

• **VICTOR HARBOR Telephone (08) 8552 5164**
95 Victoria Street, VICTOR HARBOR

• **GOOLWA Telephone (08) 8555 2825**
29 Hutchinson Street, GOOLWA

• **HAPPY VALLEY Telephone (08) 8381 6011**
Cnr. Kenihan & Regency Roads, HAPPY VALLEY

IMPORTANT: Please refer to the "Selection Use and Maintenance of Stratco Steel Products" brochure. Zincalume® is a registered trademark of BHP

NEW SOUTH WALES

HUNTINGWOOD Telephone (02) 9672 1688

15 Liberty Road, HUNTINGWOOD

• **CAMPBELLTOWN Telephone (02) 9672 1688**
22 Blaxland Road, CAMPBELLTOWN

• **PENRITH Telephone (02) 9672 1688**
125 Coreen Avenue, PENRITH

WESTERN AUSTRALIA

CANNING VALE Telephone (08) 9455 1911

Cnr. Bannister Rd & Hopewell St, CANNING VALE

• **MALAGA Telephone (08) 9249 4911**
Cnr. Marshall Road & Energy Street, MALAGA

• **BUNBURY Telephone (08) 9791 4200**
Cnr. Strickland Street & Zaknic Place, BUNBURY

• **KALGOORLIE Telephone (08) 9022 4805**
Cnr. Cassidy & Dugan Streets, KALGOORLIE

VICTORIA

KILSYTH Telephone (03) 9728 4200

73 - 75 Canterbury Road, KILSYTH

• **KILSYTH SOUTH Telephone (03) 9711 6922**

2/158 Canterbury Road, KILSYTH

• **THOMASTOWN Telephone (03) 9465 6333**
241 Settlement Road, THOMASTOWN

QUEENSLAND

CRESTMead Telephone (07) 3489 5100

179 Magnesium Drive, CRESTMEAD

• **TOOWOOMBA Telephone (07) 4638 9322**
167 Herries Street, TOOWOOMBA

• **VIRGINIA Telephone (07) 3489 5109**
2037 Sandgate Road, VIRGINIA

• **CABOOLTURE Telephone (07) 5499 3055**
17 Concorde Place, CABOOLTURE

• **MAROOCHYDORE Telephone (07) 5476 5920**
Cnr. Maroochy Road & Pike Street
KUNDA PARK, MAROOCHYDORE

• **GOLD COAST Telephone (07) 5525 1511**
108 Eastlake Street, CARRARA

NORTHERN TERRITORY

BERRIMAH Telephone (08) 8947 2299

780 Stuart Highway, BERRIMAH

• **ALICE SPRINGS Telephone (08) 8952 2826**
1 Brown Street, ALICE SPRINGS

© Copyright STRATCO (AUSTRALIA) PTY LTD
AUGUST 2003 (A.C.N. 007 550 754) 5K/9/03