

THE STRATCO UNIVERSAL SYSTEM

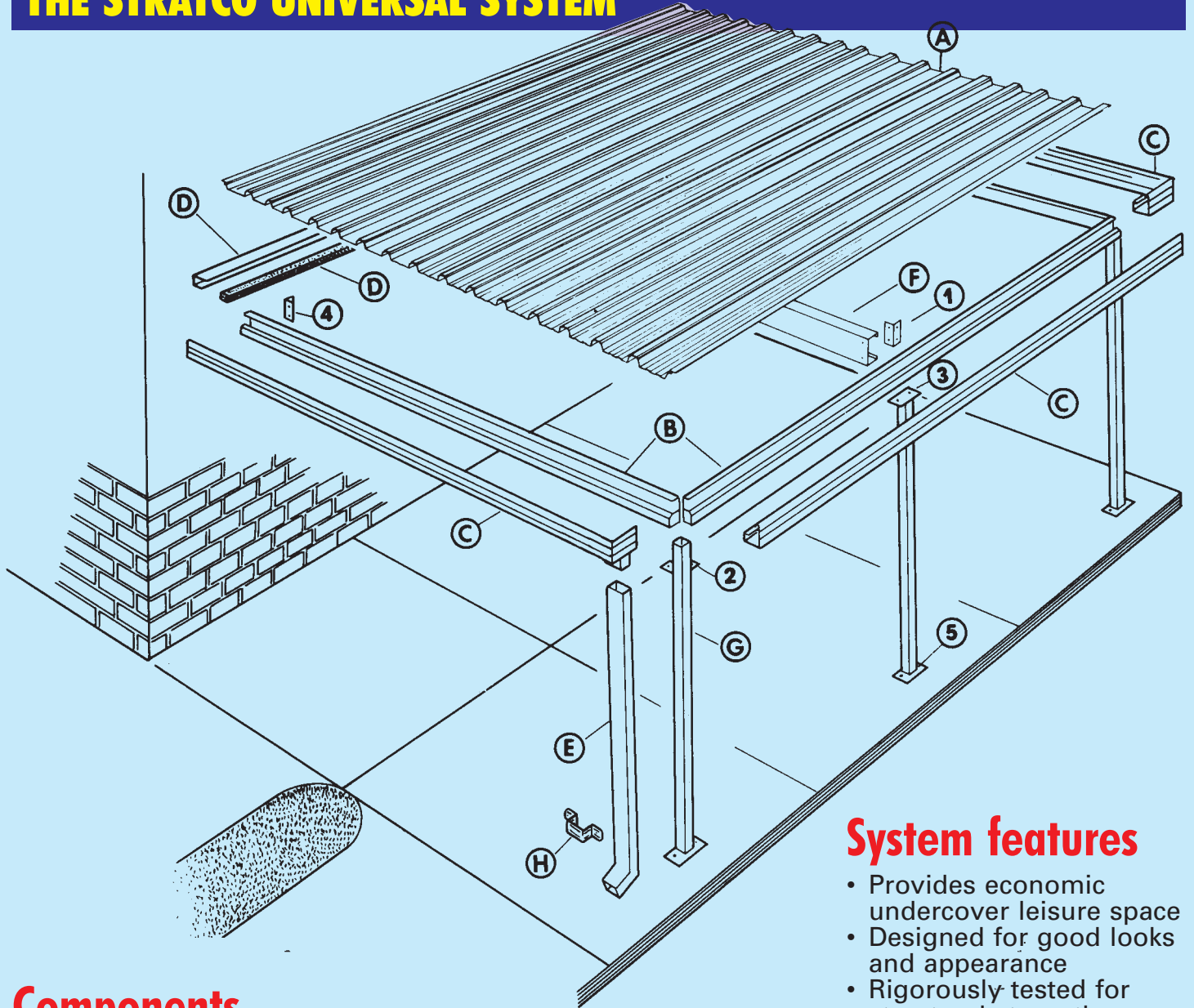

Components

- A** ROOF DECKING
- B** FASCIA TRUSS
- C** V.F. GUTTERS
- D** BACK CHANNEL & B.I.P.
- E** DOWNPIPES
- F** INTERMEDIATE BEAM
- G** POSTS
- H** DOWNPIPE STRAPS

System features

- Provides economic undercover leisure space
- Designed for good looks and appearance
- Rigorously tested for structural strength
- Wide range of colour combinations
- System specifications pass building and council regulations
- Clean lines and aesthetic appeal

System Connections

- 1** VERANDAH ANGLE BRACKETS (to connect intermediate truss to fascia truss)
- 2** CORNER POSTS
- 3** INTERMEDIATE POSTS
- 4** VERANDAH ANGLE BRACKETS (to connect truss to back wall)
- 5** FOOTING BRACKET (to connect post to ground)

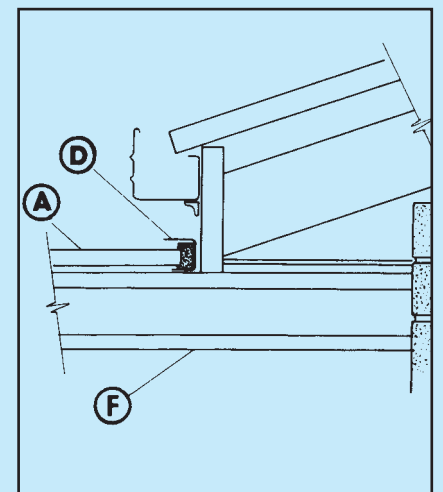
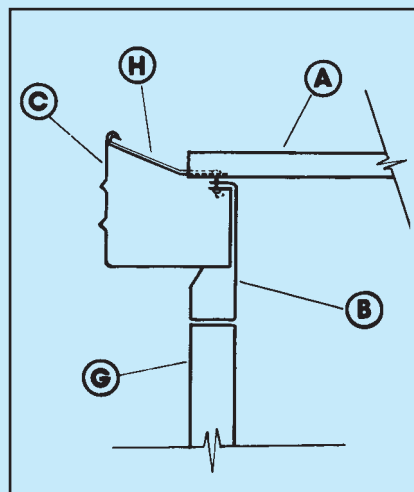

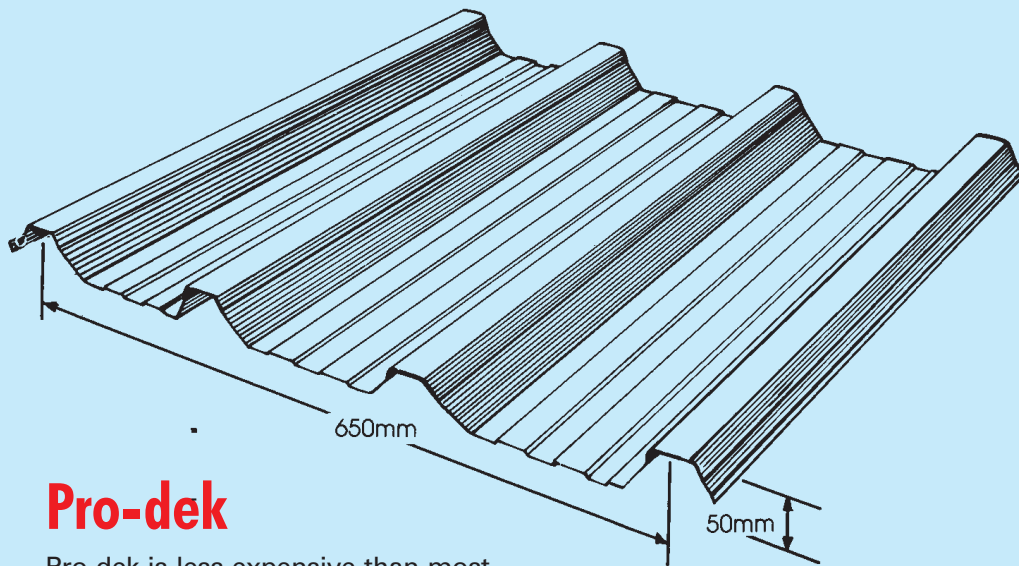

Pro-dek

Pro-dek is less expensive than most other roof deckings with similar capabilities, because Pro-dek is capable of long, unsupported spans. It can also save you money by reducing the number of purlins and girts needed.

Translucent Sheeting

Fibreglass translucent sheeting is available as an option to allow additional light under your verandah. Ideally placed adjacent to windows, each panel is of the same size and contour of the Pro-dek metal sheet. It is produced from robust 2400gsm (8 oz.) material for additional strength.

Free-standing Units

Free-standing units are available for use as carports or verandahs where attaching to the home is impractical. These units use extra strength galvanised columns which must be concreted into the ground. Various heights are available to suit boats, caravans, horse floats, etc. Contact your nearest Stratco Office for details.

Spans

For full details and specifications please refer to the STRATCO "VERANDAH, PATIO AND CARPORT SPAN TABLES".

Many Colour Options

A wide choice of colours are available in gutters, downpipes and roofing products. Contact your nearest Stratco office as colour availability varies between states and range of products.

Maintenance

For specifications on maintenance, fixing methods, handling, storage and a wide range of other important facts, consult the "Selection Use and Maintenance of Stratco Steel Products" brochure. Failure to maintain a regular maintenance programme may result in a significantly reduced lifespan.

Your new Universal Verandah should receive a wash and wipe down with a soft broom, mop or sponge as frequently as you should wash your car to maintain its duco. In marine or industrial environments, or in unwashed areas, frequency should be significantly increased. This maintenance must be frequent enough to prevent the accumulation of dust, salts and pollutants or any other material which will reduce the life of the product.

All technical data and information is correct at the time of publication. Stratco reserve the right to alter dimensions, tolerance etc. without notice.

B. Fascia Truss

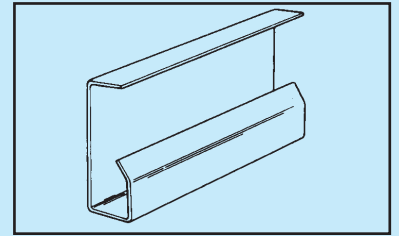

The Stratco Fascia Truss is specially designed as a strong structural member capable of providing a rigid support for Stratco roofing.

C. V.F. Gutter

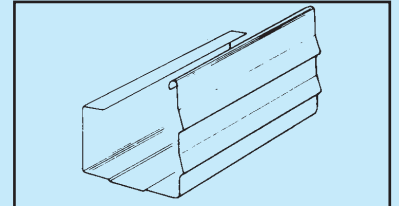

This attractive gutter is ideally suited to carport applications being easy to install and highly efficient. It fits snugly into the fascia truss.

D. Back Channel

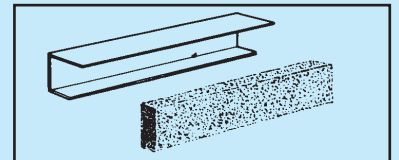

The back channel provides a secure support for the roof deck and is fixed to the house fascia or wall. The bitumen impregnated polyurethane (B.I.P.) strip provides effective weather-proofing in a verandah application.

E. Downpipes

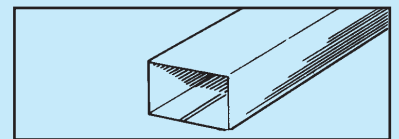

A range of square or rectangular downpipes is available in either coloured or galvanised finishes.

F. Intermediate Beam

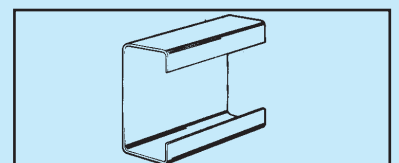

'C' Section. Stratco 'C' sections are high tensile galvanised structural members especially designed to span long distances.